

▶ THERE'S
NOTHING
LIKE IT!



STACER

DAWN DUTY
The first rays of sun illuminate mist rising from the glassy water, disturbed only by the sounds of the waking birds morning calls and water lapping against your Stacer... now that's dawn duty.



FAMILY MOMENTS

Whether it's their first fish or the one that got away, there are endless family moments just waiting to be lived in a Stacer. Live, laugh and play.



CHOOSE YOUR



ADRENALIN SEEKING

If it's boats that get your blood pumping and your heart thumping, then why wait? Whether its offshore fishing, wakeboarding or water skiing, start your next thrill-seeking adventure with a Stacer!

TIME OUT

Don't get stuck on auto pilot, take a time out from the 'everyday' and make your weekends special. Recharge your batteries with no computers, emails, video games... just quality time with you, friends and family.





ROMANTIC ESCAPES

Always dream of escaping to your own private beach for a romantic break? Make dreams next weekends holiday plans with your Stacer and explore your local waterways for that ideal secluded spot.

PIONEERING

Look to the open ocean and long for adventure? Longing to explore and discover new untouched waterways? Embrace your inner explorer, Stacer will get you there.

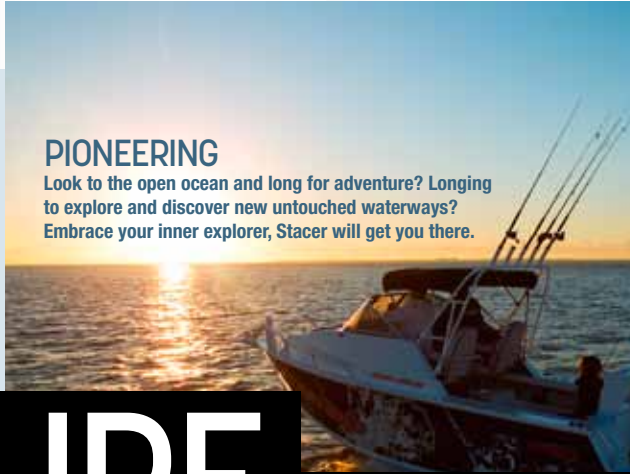

R ADVENTURE

STACER.COM.AU <<

no matter what
your dreams may be,
Stacer has you covered!



WHY CHOOSE STACER

- + Wide Dealer Network
- + A Solid History
- + Strength & Durability
- + Value for Money
- + Extensive Range
- + Superb Design

A LIFETIME OF BOATING

At Stacer we are dedicated to providing quality products that deliver superior value and performance. We have over 40 years experience in boating and are a renowned leader in the aluminium boat industry.



NOT JUST A BOAT!

When you buy a Stacer, you get so much more than just a boat! As a Stacer customer, you're backed by our 3 year factory warranty for peace of mind. Stacer also has a network of over 60 qualified marine retailers nationwide, so you can feel confident knowing there is always a dealership nearby to assist with any service or warranty enquiries.

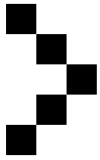

As a Stacer owner you can enjoy all the benefits of a stylish, dependable Australian made and owned product that represents all that is youthful and fun.



STACER TRAILERS

Cradle your pride and joy with a purpose built steel galvanised or aluminium Stacer trailer.

Each model has been perfectly matched with a Stacer trailer to make towing, launching and retrieving a breeze. Our trailers have been rigorously tested to withstand even the toughest journey, for more information refer to page 57.

KEEPING BOATING FUN!

At Stacer, we want to eliminate the hassle and make buying your boat FUN! Stacer's Ready2Go packages keep it simple, so you can get out on the water faster! Simply choose your favourite boat and then it is paired with the relevant Stacer Trailer and Evinrude outboard. Your package is then assembled, fitted and pre-rigged at the Stacer factory and covered by our 3 Year factory warranty, ready for your first outing!



EASY-FOLD REAR LOUNGE

Taking time out is even easier with our new 'Easy Fold' rear lounge. In one fluid motion the lounge folds down from being flush with the transom... so a comfy seat is never far away, and never underfoot!

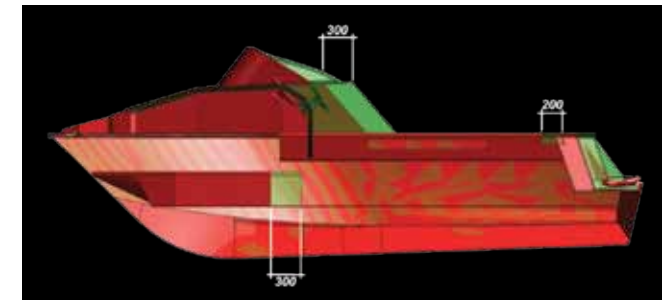

■ OLD ■ ADDITIONAL SPACE

LOW PROFILE SPORTS DECK

Our new Low Profile Sports Deck combines a raised top deck with a low profile windscreen for an improved driving position and a modern, sportier look. The new LPSD is featured on Baymaster (excl 449), Easy Rider and Sportster models.



BIG BUNKS

Our new range of Stacer cabins are perfect for families and fishos alike; now with larger 6 foot bunks on 589 & 639 models, even more cockpit space and a larger more protected cabin design.

INNOVATIVE DESIGNS

Using the latest technology and innovative design Stacer produces a range of hull designs that deliver outstanding performance on the water.

EVO HULLS

We're proud of our new hull design, but we're also proud of our original EVO Hull which has a solid reputation for quality and reliability. Using a reverse chine design The EVO Hull continues to be used on many of our smaller models delivering superb stability and performance.

EVO ADVANCE

Stacer's new EVO Advance Hull brings a new height to boating adventure offering the perfect combination of storage, stability and rough water performance. Built on the foundations of the renowned EVO Hull, the EVO Advance Hull is our most advanced hull design.

PROLINE SPORTS HULL

The Proline Sports Hull is featured on the Proline range and sees the already wide beam of the Proline range come forward to the bow to provide superb stability for casting and the v-shape delivers a smooth ride.

SF SPORTS HULL

Exclusive to the SF Series models, the SF Sports Hull combines the sleek spray deflecting plate side sheets of the EVO Advance Hull with a concave high performing bottom sheet design. The result is a high performing hull that glides over the water and provides superb stability at rest. The hull also offers a unique tournament style transom with more usable space and storage.



EVO
ADVANCE

Sharper Entry, Smoother Ride

The EVO Advance Hull takes Stacer's design principals to a whole new level. Featuring the combination of a sharper bow design (1) and a deeper V (2) the EVO Advance Hull delivers a smoother ride and impressive overall performance.

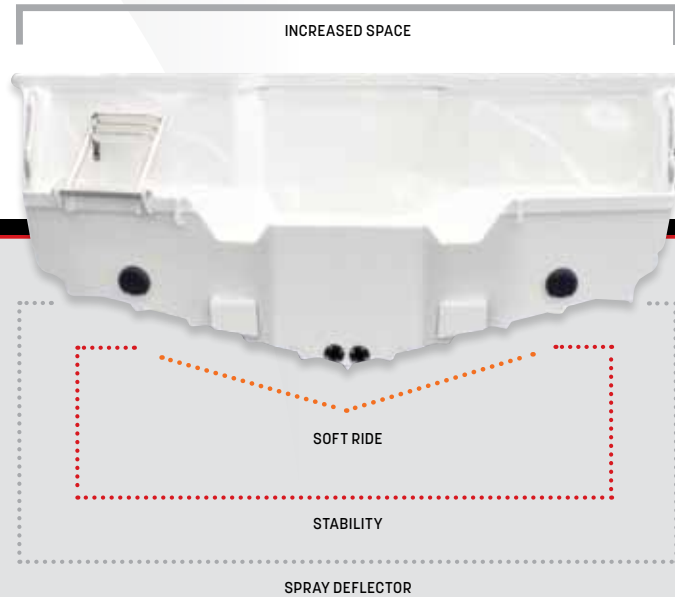
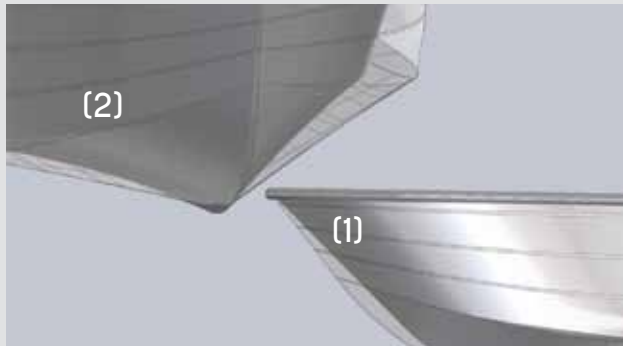

Increased Space

The new transom of the EVO Advance Hull was designed to increase cockpit space and also make boarding easy by enclosing engine cables inside the transom keeping the boarding platform obstruction free.

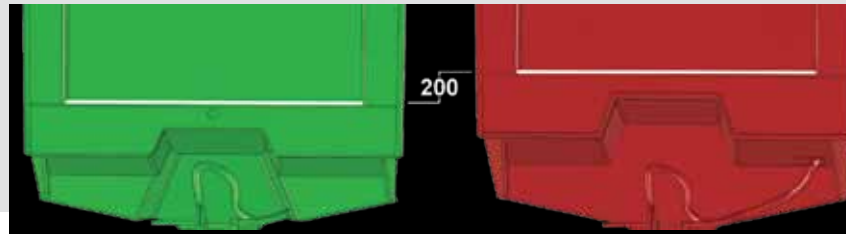

■ The EVO Advance Hull delivers on average 200mm more internal space.

Gunnel Bump Rubber

Stacer's larger models are built tough with a Gunnel Bump Rubber to keep your paint in top condition. This rubber insert runs along the gunnels protecting your boat when pulling up at a jetty or coming alongside other vessels.



Level Flotation

Level Flotation is standard across the majority of the Stacer range, making our boats some of the safest on the water. Level Flotation enables Stacer boats to remain level and upright when swamped in calm water with passengers and cargo on board. For advice on whether your Stacer features Level or Basic flotation, contact your local dealer.

POWER FOR ANY NEED

PERFECT ENGINE CHOICE

Powering with an Evinrude E-TEC engine will give you even more time on the water.

You will benefit from Evinrude outboard engines low maintenance requirements - no dealer scheduled maintenance for 3 years or 300 hours - and superior fuel efficiency. And with class leading power and torque combined with greater control and handling, Evinrude offers enhanced outboard performance. Old Tech or E-TEC. The choice is yours.



Easy to own & operate

- No scheduled dealer servicing for the first 3 years or 300 hours.
- No break-in period of oil changes.



Clean & quiet

- Cleanest engine on the water.
- Quietest engine on the water.



Durability, quality & reliability

- Fewer parts. Fewer problems.
- S.A.F.E. system; which automatically switches your engine to protect mode in the unlikely event of loss of oil or overheating.



Power & performance

- Best in class acceleration.
- Best in class fuel-efficiency.





POWER FOR ANY BUDGET



MORE AFFORDABLE

When you buy a Stacer-Vortex Ready2Go Boat, Motor, Trailer Package you're buying a product backed and owned by Australia's largest Aluminium boat manufacturer.

With a Stacer-Vortex Package getting into boating has never been easier on the wallet. We're proud to say that Vortex engines are on average approximately 25% more affordable than a comparable outboard, so you can get into the boating package you've always wanted. Look no further than a Vortex outboard, backed by a 3 year warranty for peace of mind.

The Vortex range currently encompasses over 20 models with more still to come, starting with 2.5hp and ranging up to 40hp. Power your Stacer boating package with either a gutsy Vortex 2 stroke or fuel efficient 4 stroke engine in a tiller-steer or forward control configuration. The Vortex range also includes engines in a choice of manual or electric start.

For more information, specifications and images of the Vortex range visit www.vortexmarine.com.au

Vortex Warranty

Buying a boat is a big decision and can also be a big investment. With a Vortex outboard engine you receive value for money as well as peace of mind.

All Vortex engines are covered by a 3 year warranty backed by Telwater Australia's largest aluminium boat manufacturer. Telwater has over 20 years' experience in manufacturing and distributing Marine products. Now that's peace of mind!

3 YEAR WARRANTY

MORE FOR YOU

WWW.STACER.COM.AU

Stacer Build my boat

Design your dream boat with the new Stacer 'Build My Boat' function. Customise your chosen model with our range of options, colours, stripes and wraps and then submit your request for a quote with your local dealer. Be the envy of every fisherman on the water with your one of a kind custom Stacer.

Find and compare your Stacer

Feeling a bit unsure about which model will suit your needs? Use our 'Find Your Stacer' tool to narrow down your search. Fill in the number of people you would like the boat to accommodate and also the size of your ideal boat. Once you have narrowed down the search, you can compare the specs of the boats on your list.

Stacer out and about

Out and about and need some Stacer information? Not to worry, the new Stacer mobile site has everything at your fingertips. Scan this QR code to visit our website and look out for these throughout our catalogue.

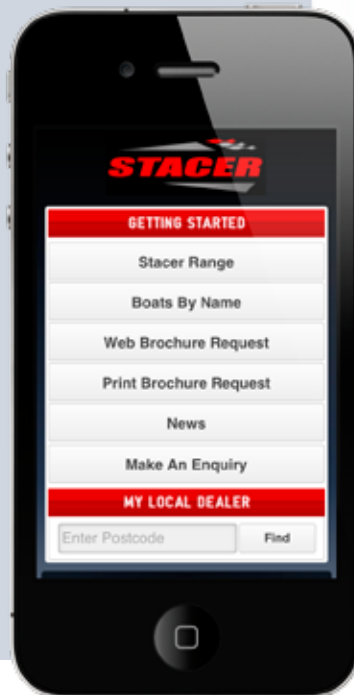

More Online

There's more information than ever before on www.stacer.com.au with news, reviews and images galleries of each model at your fingertips.

CHOOSE YOUR ELECTRONICS



LOWRANCE

Lowrance Mark-5 and Elite-5 HDI:

Available in a 5" combo or sounder only with both down scan and traditional sonar available.

STANDARD FIT

Mark-5

NEW! Hybrid Dual Imaging™

Elite-5 HDI

LOWRANCE

Elite-7 HDI

Lowrance Elite-7 HDI:

NEW! Hybrid Dual Imaging™ Available in a 7" widescreen combo, sounder or chartplotter.

UPGRADE



Elite-7 HDI

LOWRANCE

HDS Gen2 HDS Gen2 Touch

Lowrance HDS Gen2 & Gen2 Touch

NEW! HDS-Gen2 and Gen2 Touch available in sizes between 5" and 12".

UPGRADE



HDS-5 Gen 2

HDS-12 Gen 2 Touch

What's your pick?

Features:

	Lowrance HDS Gen 2 Touch	Lowrance HDS Gen 2	Lowrance Elite-7 HDI	Lowrance Mark & Elite
Networkable Plug and play any Lowrance module.	●	●		
StructureScan™ The ultimate in reality echosounding. * Requires LSS-2 Module.	●	●*		
DownScan Imaging See underwater environments in a clear, new way. * With DSI Models.			●	●+
Broadband Radar A revolution in radar.	●	●		
Built-in Broadband Sounder Incredible echo clarity. ‡ Elite models only.	●	●	●	●‡
Transducer included Supplied with a standard transducer.			●	●
Touch Screen Easy to use touch screen control.	●			
Insight Mapping Insight Genesis™ allows you to create free customized maps based on your own survey data.	●	●	●	



OPEN BOATS

STACER.COM.AU «

Smaller Stacer open boats load easily atop 4WDs, utes, camper trailers and caravans without weighing them down and there's a boat in our range to suit any budget.

Stacer's open boats feature wide beams and high sides making them roomy and safe to operate. Our open boats are easy to drive, economical and handle well in a variety of conditions whatever your boating experience. Being aluminium they simply require a spray down with fresh water after use...
Until next weekend of course!





THE RANGE

309 Stinga // 319 Seasprite
359 Seasprite // 369 Seasprite
379 Seasprite // 399 Seasprite
429 Rampage // 429 Seahorse
449 Seahorse // 469 Seahorse
489 Seahorse // 529 Seahorse

OB

OPEN BOATS

FEATURING

379 SEASPRITE
Stable Wide Beam
Bench Seats
Glove Box
Solid Corners



429 SEAHORSE
EVO Hull
Carpeted Low Floor
Carpeted Fuel Tank Rack
Deep Freeboard



OB

OPEN BOATS



309 Stinga

This is the little boat that packs a punch! With tough slab sides and 2mm bottomsheets it's ready for action with a 15hp outboard... it's the perfect first boat.

319 Seasprite

Good things come in small packages and the 319 Seasprite is no exception. This light and manoeuvrable model can be carried just about anywhere.

309 STINGA

FEATURED BOAT // A



B // 319 SEASPRITE



379 SEASPRITE

BOW HANDLES
ANCHOR SHELF
BENCH SEATS

399 SEASPRITE

SOLID CORNERS
ROWLOCK BLOCKS
GLOVE BOX



359 Seasprite

The small and mighty 359 Seasprite is lightweight and perfect for making short trips through estuaries and rivers.

369 Seasprite

Fitted with a glove box as standard, the 369 Seasprite is a small model with big value.

C // 359 SEASPRITE



D // 369 SEASPRITE



E // 379 SEASPRITE



F // 399 SEASPRITE



379 Seasprite

The 379 Seasprite has added length and beam giving more room for your boating gear. An upgrade from a smaller 'dinghy' with room to move and a faster planning speed, this little beauty is the boat for you.

399 Seasprite

The 399 Seasprite is a tough skinned open boat great for taking out in a range of waters. There is no missing the perfect catch in this stable ride.

MEASUREMENTS	359 SEASPRITE	369 SEASPRITE	379 SEASPRITE
LENGTH MAXIMUM:	3.21M	3.19M	3.55M
LENGTH OF HULL:	3.21M	3.19M	3.55M
BEAM:	1.41M	1.39M	1.45M
DEPTH:	0.82M	0.78M	0.79M
LENGTH ON TRAILER:	5.00M	4.63M	4.63M
HEIGHT ON TRAILER:	1.40M	1.50M	1.55M
BOTTOMSIDES:	2.00MM	1.35MM	1.60MM
TOPSIDES:	1.60MM	1.35MM	1.60MM
TRANSOM MATERIAL:	2.00MM	1.60MM	1.60MM
TRANSOM SHAFT LENGTH:	S/S	S/S	S/S
WEIGHT (BOAT ONLY):	70KG	58KG	76KG
MIN. HP:	6HP	5HP	8HP
MAX. HP:	15HP	8HP	15HP
MAIN MOTOR WEIGHT:	58KG	42KG	58KG
NUMBER OF PEOPLE (BASIC):	3	4	4
NUMBER OF PEOPLE (LEVEL):	N/A	N/A	N/A
PACKAGE TRAILER:	TQLITE10	TQLITE10	TQLITE10

STANDARD	359 SEASPRITE	369 SEASPRITE	379 SEASPRITE
ANCHOR GUSSET	+	+	+
HANDLES: BOW (1)	+	+	+
HANDLES: TRANSOM (2)	+	+	+
ROWLOCK BLOCKS (SET)	+	+	+
SEAT: BENCH SEAT FLOTATION	+	+	+
SEAT: FRONT & REAR BENCH SEAT	+	+	+
SOLID CORNERS	+	+	+

OPTIONS	359 SEASPRITE	369 SEASPRITE	379 SEASPRITE
BIMINI & ENVELOPE	+	+	+
HULL STRIPE	+	+	+
PAINT: TWO TONE	+	+	+
PAINTED HULL	+	+	+
RAILS: AFT SHORT SIDE	+	+	+
RAILS: LOW BOWRAILS	+	+	+
ROD HOLDERS (2)	+	+	+
TRANSDUCER BRACKET	+	+	+
VINYL WRAP	+	+	+

MEASUREMENTS	379 SEASPRITE	379 SEASPRITE	399 SEASPRITE
LENGTH MAXIMUM:	3.75M	3.85M	3.95M
LENGTH OF HULL:	3.75M	3.85M	3.95M
BEAM:	1.62M	1.75M	1.75M
DEPTH:	0.81M	0.91M	0.95M
LENGTH ON TRAILER:	5.20M	5.20M	5.20M
HEIGHT ON TRAILER:	1.60M	1.60M	1.60M
BOTTOMSIDES:	1.60MM	1.60MM	1.60MM
TOPSIDES:	1.60MM	1.60MM	1.60MM
TRANSOM MATERIAL:	1.60MM	1.60MM	1.60MM
TRANSOM SHAFT LENGTH:	S/S	S/S OR L/S	S/S OR L/S
WEIGHT (BOAT ONLY):	80KG	98KG	109KG
MIN. HP:	15HP	15HP	15HP
MAX. HP:	16HP	25HP	30HP
MAIN MOTOR WEIGHT:	58KG	87KG	120KG
NUMBER OF PEOPLE (BASIC):	4	4	5
NUMBER OF PEOPLE (LEVEL):	N/A	N/A	N/A
PACKAGE TRAILER	TQLITE13	TQLITE13	TQLITE13

STANDARD	379 SEASPRITE	379 SEASPRITE	399 SEASPRITE
ANCHOR GUSSET	+	+	+
GLOVE BOX WITH DRINK HOLDERS	+	+	+
HANDLES: BOW (1)	+	+	+
HANDLES: TRANSOM (2)	+	+	+
ROWLOCK BLOCKS (SET)	+	+	+
SEAT: BENCH SEAT FLOTATION	+	+	+
SEAT: FRONT & REAR BENCH SEAT	+	+	+
SOLID CORNERS	+	+	+

OPTIONS	379 SEASPRITE	379 SEASPRITE	399 SEASPRITE
BIMINI & ENVELOPE	+	+	+
HULL STRIPE	+	+	+
PAINT: TWO TONE	+	+	+
PAINTED HULL	+	+	+
RAILS: FULL LENGTH SIDERAILS	+	+	+
RAILS: AFT SHORT SIDE	+	+	+
RAILS: LOW BOWRAILS	+	+	+
ROD HOLDERS (2)	+	+	+
TRANSDUCER BRACKET	+	+	+
VINYL WRAP	+	+	+

429 SEAHORSE

FEATURED BOAT // A



429 Seahorse

The 429 Seahorse is the ideal model for exploring local waterways and with its high sides, beamy interior and 2mm bottomsides this model can reach tight corners with ease.

429 Rampage

The 429 Rampage is the rising star of Stacer's open boat range - this gutsy model has all the standard features on a keen fisherman's wish list including casting platform, carpeted low floor and side pockets.



B // 429 RAMPAGE

429 Rampage

- CASTING PLATFORM AND STORAGE
- LOW CARPETED FLOOR
- CARPETED FUEL TANK RACK

429 Seahorse

- CARPETED FUEL TANK RACK
- CARPETED FULL FLOOR BETWEEN SEATS
- ANCHOR GUSSET

449 Seahorse

The 449 Seahorse embodies all the benefits of an open boat: manoeuvrability, fuel efficiency and durability. Added size makes this boat suited to enclosed waters and open bays.

C //449 SEAHORSE



469 Seahorse

Take the family out for a great day on the water with the 469 Seahorse. This model can be optioned up with a fish finder so the perfect catch has nowhere to hide.

D //469 SEAHORSE



E //489 SEAHORSE



489 Seahorse

A step up in size the 489 Seahorse is a tough skinned open boat that offers a balance between internal work space and increased horsepower.

F //529 SEAHORSE



529 Seahorse

The 529 Seahorse is the biggest in the Seahorse range, with the largest beam of any Stacer open boat. This boat can hold its own in choppy water and is ideal for the skipper who needs the extra elbow room.

MEASUREMENTS	429 RAINIDGE	429 SEAHORSE	449 SEAHORSE	469 SEAHORSE	489 SEAHORSE	529 SEAHORSE
LENGTH MAXIMUM:	4.27M	4.27M	4.49M	4.69M	4.90M	5.35M
LENGTH OF HULL:	4.27M	4.27M	4.49M	4.69M	4.90M	5.35M
BEAM:	1.87M	1.90M	2.05M	2.20M	2.20M	2.32M
DEPTH:	1.07M	0.98M	1.10M	1.10M	1.10M	1.29M
LENGTH ON TRAILER:	5.40M	5.50M	5.65M	6.16M	6.16M	6.85M
HEIGHT ON TRAILER:	1.60M	1.60M	1.80M	1.80M	1.80M	1.80M
BOTTOMSIDES:	3.00MM	2.00MM	3.00MM	3.00MM	3.00MM	3.00MM
TOPSIDES:	1.60MM	1.60MM	1.60MM	1.60MM	1.60MM	2.00MM
TRANSOM MATERIAL:	3.0MM	2.00MM	3.00MM	3.00MM	3.00MM	3.00MM
TRANSOM SHAFT LENGTH:	L/S	S/S OR L/S	L/S	L/S	L/S	L/S
WEIGHT (BOAT ONLY):	200KG	164KG	220KG	240KG	260KG	285KG
MIN. HP:	25HP	30HP	30HP	40HP	40HP	50HP
MAX. HP:	40HP	40HP	50HP	50HP	60HP	60HP
MAIN MOTOR WEIGHT:	120KG	120KG	120KG	120KG	121KG	121KG
NUMBER OF PEOPLE (BASIC):	4	5	5	6	6	6
NUMBER OF PEOPLE (LEVEL):	N/A	4	4	5	5	5
PACKAGE TRAILER	TQLITE13	TQLITE	TQ46	TQ48	TQ48	TQ51VB
STANDARD						
3 YEAR WARRANTY	+	+	+	+	+	+
ALLOY CLEAT ON FRONT DECK			+	+	+	+
ANCHOR GUSSET		+		+	+	+
ANCHORWELL	+					
EVO HULL	+	+	+	+	+	+
FLOOR: CARPETED FUEL TANK RACK	+	+	+	+	+	+
FLOOR: CARPETED FULL BETWEEN SEATS			+	+	+	+
FLOOR: CARPETED LOW FLOOR	+	+				
FLOOR: CASTING PLATFORM	+					
FRONT DECK	+	+	+	+	+	+
GLOVE BOX WITH DRINK HOLDERS		+	+	+	+	+
HANDLES: BOW (2)		+	+	+	+	+
HANDLES: TRANSOM (2)		+	+	+	+	+
RAILS: SHORT LOW BOWRAILS	+					
RAILS: AFT SHORT SIDE	+					
ROWLOCK BLOCKS (SET)		+				
SEAT: BENCH SEAT FLOTATION	+	+	+	+	+	+
SEAT: FRONT BENCH SEAT	+	+	+	+	+	+
SEAT: REAR BENCH SEAT	+	+	+	+	+	+
SIDE POCKETS (2)	+					
SOLID CORNERS	+	+	+	+	+	+
TRANSDUCER BRACKET			+	+	+	+
TRANSOM STEP & RAIL	+					
OPTIONS						
ALLOY CLEAT		+				
ANCHORWELL		+	+	+	+	+
COVERS: BIMINI & ENVELOPE	+	+	+	+	+	+
BOTTOMSIDE 3.0MM		+				
CONSOLE: SIDE CONSOLE		+	+	+	+	+
EXTRUDED SIDE DECKS	+	+	+	+	+	+
FLOOR: CARPETED FULL BETWEEN SEATS	+					
FLOOR: CASTING PLATFORM		+	+	+	+	+
FLOOR: REAR CASTING PLATFORM		+	+	+	+	+
HULL STRIPE	+	+	+	+	+	+
PAINT: TWO TONE	+	+	+	+	+	+
PAINTED HULL	+	+	+	+	+	+
RAILS: SHORT LOW BOWRAILS	+	+	+	+	+	+
RAILS: AFT SHORT SIDE		+	+	+	+	+
RAILS: LOW BOWRAILS		+	+	+	+	+
ROD HOLDERS (2)	+	+	+	+	+	+
ROWLOCK BLOCKS (SET)		+	+	+	+	+
SEAT: SKIPPER		+	+	+	+	+
SIDE POCKET		+	+	+	+	+
TRANSDUCER BRACKET	+	+	+	+	+	+
TRANSOM STEP & RAIL		+	+	+	+	+
UNDERFLOOR SEAT POSITION		+	+	+	+	+
VINYL WRAP	+	+	+	+	+	+

CHOOSE YOUR OPTION

Accessory Kit Includes:
 + Battery Box + Isolator Switch + Auto Bilge Pump
 + Switch Panel + Navigation Lights
 For more accessory options visit www.stacer.com.au

SIDE POCKET



BAIT BOARD



3/4 REAR FOLDING LOUNGE & TRANSOM BACK REST



SKIPPER SEAT



MARITIME SEAT



ROD RACK LOCKER

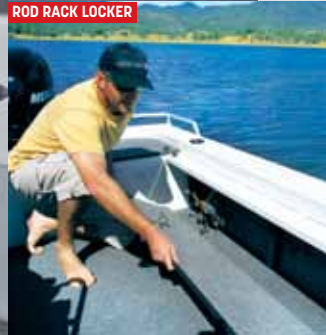

SPORTS CONSOLE



TELESCOPIC LADDER



SKI POLE



SIDE CONSOLE



TRANSOM STEP



TRANSOM DOOR SHUT



FUEL TANK RACK



GME CD/RADIO



TRANSOM MOUNTED LIVE BAIT TANK



FISH BOX SEAT



BAIT BOARD & LIVE BAIT TANK



LOWRANCE SOUNDER



TRANSOM DOOR OPEN



BURLEY BUCKET



LOWRANCE VHF RADIO



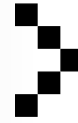
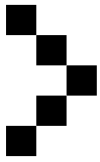

CHOOSE YOUR COLOUR

STRIPES & COLOURS

Once you have decided on your choice of boat - now is the chance to colour coordinate stripe decals and canopy colours to suit your individual taste. View the colour examples below to ensure your Stacer boat stands out from the crowd!

BOAT STRIPES

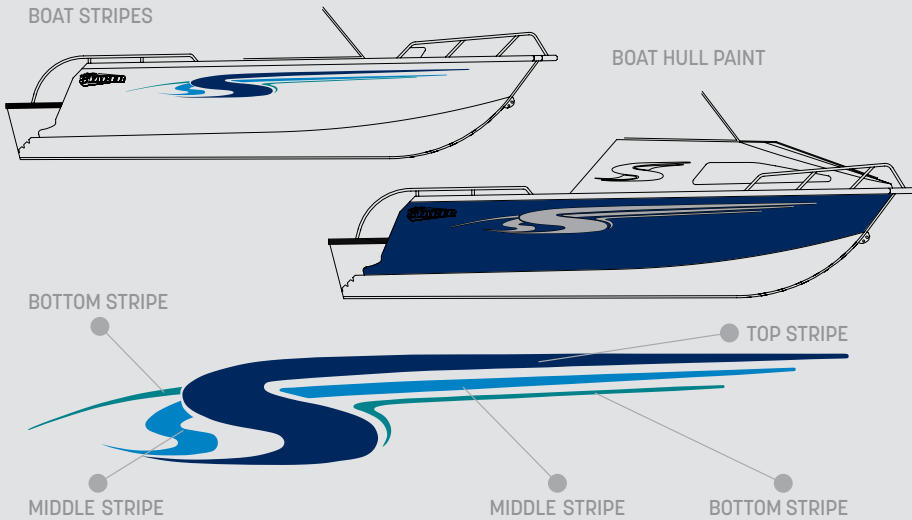

Stripe Colours >

- DARK GREEN
- TEAL
- OLYMPIC BLUE
- SAPPHIRE BLUE
- OCEAN BLUE
- BLACK
- LIGHT GREY
- BURGUNDY
- RED
- YELLOW
- TAUPE
- WHITE

Two Tone Boat Colours >

- LIGHT BLUE
- SUNBURN
- BLACK
- CLOUD GREY
- RED
- DUNE
- NAVY
- TOXIC GREEN

CHOOSE YOUR WRAP



GALAXY



TRIBAL

WRAPS Don't just stand out from the crowd - jump out!

Our UV stabilised laminate offers extra durability in four eye-catching designs, in a selection of colours.

- + choose from our four designs or supply your own
- + included under 3 year warranty
- + more resistant to chips and scratches than paint
- + high quality adhesive vinyl covered with a UV stabilised laminate for extra durability
- + applied at the factory by our specialised team

WRAP DESIGNS & COLOURS AVAILABLE:

- GALAXY** Available in Blue, Green, Orange and Red
- SPLINTER** Available in Blue, Green, Orange, Purple and Red
- TRIBAL** Available in Blue, Light Blue Green, Grey, Toxic Green and Red
- HOOKED** Available in Blue, Light Blue, Green, Toxic Green and Red



SPLINTER



HOOKED

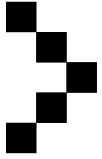

CHOOSE YOUR COVER



CANOPY



BIMINI & ROCKET LAUNCHER



BIMINI FRONT & CLEAR SIDES



NT & NQ BIMINI

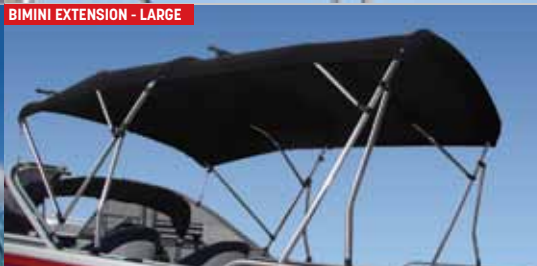

BIMINI EXTENSION - LARGE



BIMINI EXTENSION



NOMAD BIMINI



BOWRIDER TONNEAU COVER



CABIN FRONT HATCH COVER

JET BLACK

WHITE ON GREY

RED

CAPTAIN NAVY

CADET GREY

BURGUNDY

PERSIAN GREEN

PACIFIC BLUE

TOAST

Canopies and Biminis
Option up to have front and side clears or side curtains for further protection. Storm and tonneau covers are also available - all in a range of colours to match your boat!

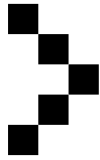

V-LOADER SERIES (TQ48VBH)

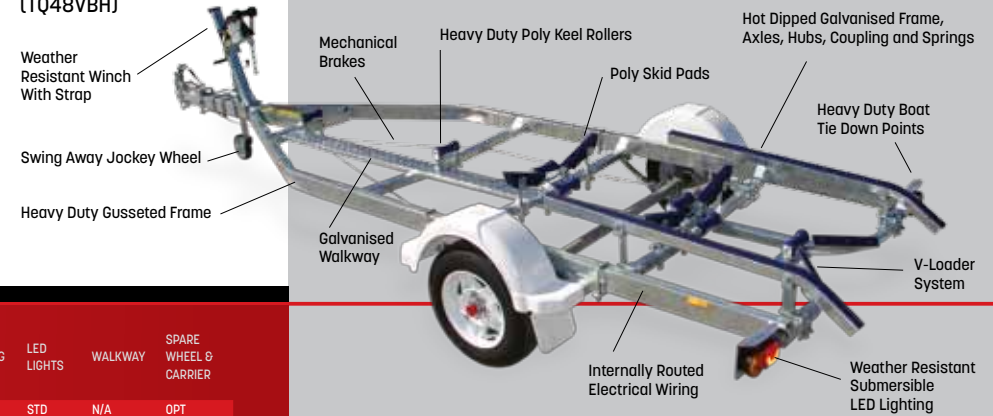

TRAILER CODE	DESCRIPTION	ATM KG	LENGTH MM	TARE WEIGHT KG	WIDTH MM	BRAKES	TYRE SIZE	ALLOY/STEEL WHEELS	GALVANISED AXLE/SPRING	WHEEL GUARDS	SWING UP JOCKEY	SEALED BEARING UNITS	LED LIGHTS	WALKWAY	SPARE WHEEL & CARRIER
V LITE SERIES															
TQLITE	460 LITE WEIGHT 650KG 13" L/SKIDS	650	4900	160	2010	N	13"	STEEL	STD	Y	DOLLY	N/A	STD	N/A	OPT
TQLITE10	370 LITE WEIGHT 600KG 10" S/SKIDS	600	4150	140	1890	N	10"	STEEL	STD	Y	DOLLY	N/A	STD	N/A	OPT
TQLITE13	400 LITE WEIGHT 600KG 13" L/SKIDS	600	4600	160	2010	N	13"	STEEL	STD	Y	DOLLY	N/A	STD	N/A	OPT
V LINE SERIES															
TQ37	310-370 V-LINE 700KG 10" S/SKIDS	700	4200	160	2000	N	10"	ALLOY	STD	Y	SMALL	STD	STD	OPT	OPT
TQ42	380-420 V-LINE 700KG 13" L/SKIDS	700	4580	160	2000	N	13"	ALLOY	STD	Y	SMALL	STD	STD	OPT	OPT
TQ46	430-460 V-LINE 749KG 13" L/SKIDS	749	5120	210	2000	N	13"	ALLOY	STD	Y	SMALL	STD	STD	STD	OPT
TQ46B	430-460 V-LINE 1000KG 13" L/SKIDS BRAKE	1000	5160	210	2000	Y	13"	ALLOY	STD	Y	SMALL	STD	STD	STD	OPT
TQ46BW	430-460 V-LINE 1000KG 13" L/SKIDS WIDE BRAKE	1000	5150	210	2240	Y	13"	ALLOY	STD	Y	SMALL	STD	STD	STD	OPT
TQ46W	430-460 V-LINE 749KG 13" L/SKIDS WIDE	749	5110	210	2240	N	13"	ALLOY	STD	Y	SMALL	STD	STD	STD	OPT
TQ48	460-480 V-LINE 749KG 13" L/SKID	749	5610	260	2000	N	13"	ALLOY	STD	Y	SMALL	STD	STD	STD	OPT
TQ48B	460-480 V-LINE 1000KG 13" L/SKID BRAKED	1000	5650	260	2000	Y	13"	ALLOY	STD	Y	8"	STD	STD	STD	OPT
V LOADER SERIES															
TQ48VB	460-480 VLOADER 1000KG 13" BRAKED	1100	5700	260	2000	Y	13"	ALLOY	STD	Y	8"	STD	STD	STD	OPT
TQ48VBH	460-480 VLOADER 1180KG 13" BRAKED	1180	5700	260	2000	Y	13"	ALLOY	STD	Y	8"	STD	STD	STD	OPT
TQ48VBHW	460-480 VLOADER 1180KG 13" BRAKED WIDE	1180	5650	260	2240	Y	13"	ALLOY	STD	Y	8"	STD	STD	STD	OPT
TQ51VB	480-510 VLOADER 1000KG 13" BRAKED	1000	5900	320	2010	Y	13"	ALLOY	STD	Y	8"	STD	STD	STD	OPT
TQ51VBH	480-510 VLOADER 1180KG 13" BRAKED	1180	5900	320	2010	Y	13"	ALLOY	STD	Y	8"	STD	STD	STD	OPT
TQ51VBH4	480-510 VLOADER 1450KG 14" BRAKED	1450	5900	320	2010	Y	14"	ALLOY	STD	Y	8"	STD	STD	STD	OPT
WIDE FRAME V LOADER SERIES															
TQ51VBH4W	480-510 VLOADER 1450KG 14" BRAKED WIDE	1450	5900	320	2270	Y	14"	ALLOY	STD	Y	8"	STD	STD	STD	OPT
TQ51VBHW	480-510 VLOADER 1180KG 13" BRAKED WIDE	1180	5900	320	2270	Y	13"	ALLOY	STD	Y	8"	STD	STD	STD	OPT
TQ58VBW	510-580 VLOADER 1450KG 14" BRAKED WIDE	1450	5980	320	2270	Y	14"	ALLOY	STD	Y	8"	STD	STD	STD	OPT
TQ61VBW	580-620 VLOADER 1450KG 14" BRAKED WIDE	1450	6650	380	2270	Y	14"	ALLOY	STD	Y	8"	STD	STD	STD	OPT
TQ61VBWT	580-620 VLOADER 2000KG 13" BRAKED WIDE TANDEM	2000	6650	420	2270	Y	13"	ALLOY	STD	Y	8"	STD	STD	STD	OPT
TQ66VBWT	620-660 VLOADER 2000KG 13" BRAKED WIDE TANDEM	2000	7120	420	2270	Y	13"	ALLOY	STD	Y	8"	STD	STD	STD	OPT
TQ70VBWT	660-700 VLOADER 2000KG 13" BRAKED WIDE TANDEM	2000	7120	420	2270	Y	13"	ALLOY	STD	Y	8"	STD	STD	STD	OPT
TQ70VBWT25	660-700 VLOADER 2500KG 14" BRAKED WIDE TANDEM	2500	7380	580	2270	Y	14"	ALLOY	STD	Y	8"	STD	STD	STD	OPT
ALUMINIUM SERIES															
TA1298S13SB	T ALLOY 1298 ATM S 13" SKID BRAKED	1298	5830	280	2240	Y	13"	ALLOY	STD	Y	8"	STD	STD	OPT	OPT
TA1400S13SB	T ALLOY 1400 ATM S 13" SKID BRAKED	1400	5830	280	2240	Y	13"	ALLOY	STD	Y	8"	STD	STD	OPT	OPT
TA1595S14SB	T ALLOY 1595 ATM S 14" SKID BRAKED	1595	6020	320	2310	Y	14"	ALLOY	STD	Y	8"	STD	STD	OPT	OPT
MULTI-ROLLER SERIES															
TAB612000T13RB	T ALLOY BLADE 610 2000 ATM T 13" ROLLER BRAKED	2000	7000	440	2240	Y	13"	ALLOY	STD	Y	8"	STD	STD	OPT	OPT
TAB652000T13RB	T ALLOY BLADE 650 2000 ATM T 13" ROLLER BRAKED	2000	7000	440	2240	Y	13"	ALLOY	STD	Y	8"	STD	STD	OPT	OPT
TAB692000T13RB	T ALLOY BLADE 690 2000 ATM T 13" ROLLER BRAKED	2000	7380	500	2240	Y	13"	ALLOY	STD	Y	8"	STD	STD	OPT	OPT
TAB692750T14RB	T ALLOY BLADE 690 2750 ATM T 14" ROLLER BRAKED	2750	7380	560	2310	Y	14"	ALLOY	STD	Y	8"	STD	STD	OPT	OPT

Standard = ✓ Not Applicable = ✗

These trailers are designed for use on sealed roads only and are not recommended for consistent off-road use. Measurements and weights are subject to variation.

Recommended trailer ATM's are based on standard boat and trailer weights, max motor weight and full fuel. Ensure that your particular requirements and intended use do not exceed these provisions. Placing the boat on a non-specified trailer may void boats warranty.

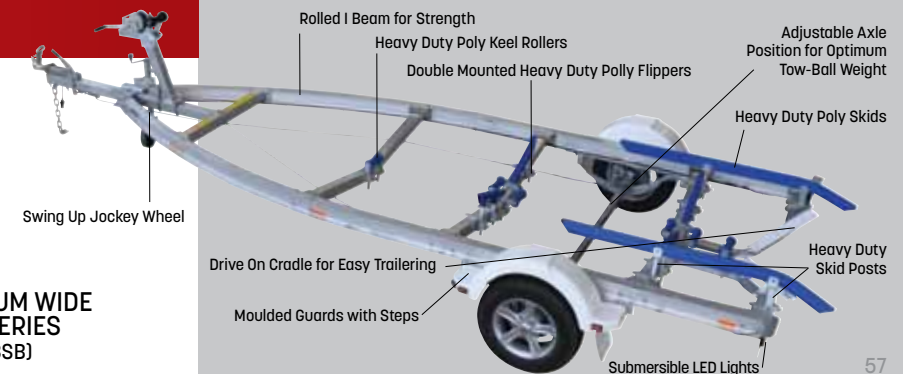

ALUMINIUM WIDE FRAME SERIES (TA1400S13SB)



For more information on the Stacer range, options available, recent news and events plus more visit stacer.com.au

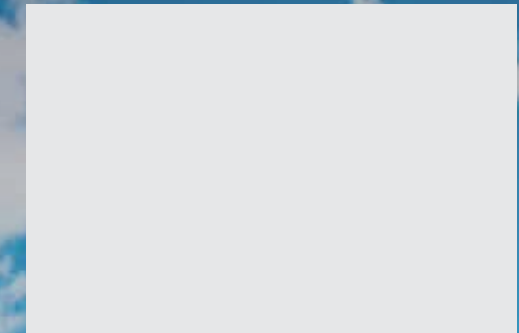

IMPORTANT

The contents of this brochure will not form part of any contractual agreement. Stacer recommends that all persons comply with their local boating regulations and are familiar with safe boating practices. This brochure is designed to provide you with an introduction to the Stacer products. Stacer reserves the right at any time, at its discretion, and without notice, to discontinue or change the features, designs, materials, colours, specifications and the prices of its products, and to either permanently or temporarily withdraw any such products from the market without incurring any liability to any prospective purchaser. Details referred to in this brochure are based on pre-production specifications and could be altered or deleted prior to the boat's sale date. Because of variations which occur in manufactured products, all capacities, measurements, dimensions and weights quoted should be taken as approximates only and are subject to change. Every effort has been made to depict boat colours and trims as realistically as possible in this brochure, however some variation may occur due to printing limitations. Always consult with an authorised Stacer dealer for the latest information with respect to features, specifications, prices, optional equipment and availability before deciding to purchase. Stacer do not offer factory direct sales or prices. For updated specifications including warranty, please refer to the Stacer website: www.stacer.com.au

*Telwater Pty Ltd 15 010 795 507
53 Waterway Drive, Coomera, Queensland 4209 Australia.
Version 3 Printed June 2013

DESIGN BY PLUVO // WWW.PLUVO.COM.AU